







# Using new scale control modeling software, Nalco Water improved the profitability of a Chilean copper mine by \$12M.



## INTRODUCTION

The mining industry faces the twin pressures of increasing demand for mineral resources and exhaustion of more easily accessible mineral reserves. As a result, mining activity continues to move into more inhospitable regions with water scarcity, and the industry needs more viable solutions to operate in arid environments.

In addition to reducing environmental impact, water management can generate substantial cost savings. The value of one cubic meter of water is estimated around \$1.00, as measured by an independent consulting team. For mines where water is scarce, water management is a huge concern for the vitality of production.

ENVIRONMENTAL IMPACT	eROI <sup>SM</sup> by Ecolab	ECONOMIC RESULTS
Reduced 1 million m3 of annual fresh water drawn	 WATER	Proposed asset value of \$1M
Increased 3,000 tons copper annually produced	 PRODUCTIVITY	\$8.5 million USD additional annual revenue
Reduced unplanned maintenance and cleaning sessions	 PRODUCTIVITY	60+ hours in labor savings and \$3,980,000 USD in reduced maintenance and cleaning costs per year
Reduced scale inhibitor dosage by 2%	 COSTS	\$176,000 USD in reduced chemical costs per year
Received 2,994 local manhours, 50 International technical support manhours, and sample and chemical analysis	 PRODUCTIVITY	\$266,468 USD in mine's reduced labor costs per year
Received Automation Systems (RDM / 3DT), Software in plants, and Automation to Control Room	 ASSETS	\$95,000 USD of equipment

**TOTAL - Increased revenue by \$8.5 million per year and saved a total cost savings of \$4.5 million per year**

eROI is our exponential value: the combined outcomes of improved performance, operational efficiency and sustainable impact delivered through our services and programs.

At one Chilean customer, every ton of ore requires approximately 2.5 m<sup>3</sup> of water. This requires a complex system for water recovery recirculating approximately 300,000 m<sup>3</sup> per day. Water management changes had increased suspended solids levels (TSS) in the site process water. This additional suspended silt caused an unprecedented increase in scale formation that blocked process pipes. As the scale started forming in critical parts of the processing plant, the customer turned to Nalco Water for immediate relief.

## SOLUTION

Nalco Water conducted a complete plant audit of the process water system using a cross-functional team of experts. A water map was created with a chemical and physical analysis of each water stream to better understand the usage demands and critical problem areas.

Once the data was collected, the team used Nalco Water's new Mining Optimizer scale modeling software to quickly evaluate the effect of different water blends. The software identified the following opportunities for optimization:

- The Mining Optimizer confirmed that the current antiscalant was correct for this application
- Mixing of water was the primary cause of the increased scaling of the process water
- Optimizing the dose points would significantly improve treatment and reduce dosage
- The service program needed to be adjusted to include different sample points to truly track process water changes

Once these results were presented, the client agreed to make several changes to their system including:

- Installation of a second dosing point to improve treatment
- Splitting dosage across two feed points to improve protection and reduce overall chemical consumption
- Instituting live digital monitoring with Nalco Water's Remote Deposit Monitor (RDM) to identify process changes instantly.
- Creating a new service plan to help manage the changes and assess the improvements.

Following Nalco Water's recommendation, the site worked to make improvements to the dosing system and began a comprehensive program to transition to the optimized dosing plan safely. The new dosing plan reduced scale formation in valves, flow meters and process water lines which immediately reduced unplanned maintenance that interrupts production.

## ENVIRONMENTAL / ECONOMIC RESULTS

By understanding the customer's process, water requirements, and what was most important to them, Nalco Water was able to tailor solutions to the site's unique variables. Through changes in dosing and reduced scale formation, the mine was able to recirculate 2,800 m<sup>3</sup>/hour of process water instead of drawing from groundwater wells, which is a costly and environmentally harmful alternative. The improved process water system and reduced scale formation resulted in a 3,140 ton increase in copper production per year, or approximately an additional \$8.5 million of revenue.

## CONCLUSION

By using the Mining Optimizer and an international team of experts along with critical local expertise, Nalco Water was able to reduce scale formation in the customer's process water lines while reducing costs. The customer was satisfied not only with the savings generated, but also the timely response to solving the problem. The Mining Optimizer allowed Nalco Water to react quickly and effectively by delivering reduced TCO and demonstrating our strategic partnership with the customer for their most critical water needs.

**Together, we are leading mining forward,  
by partnering on greater:**

- **Throughput**
- **Product Grade**
- **Production Yield**
- **Environmental/Safety Protection**
- **Water Quality**



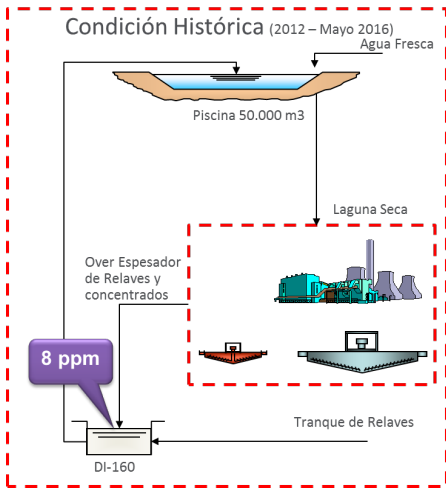

Process water system before optimization

### Condición Inicial

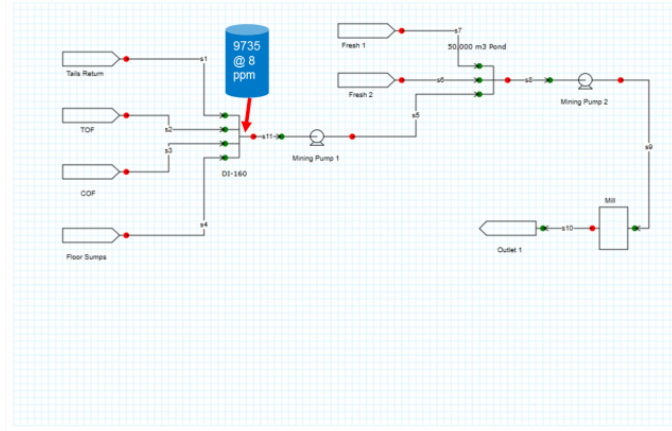

Nalco Water Mining Optimizer model prior to improvements

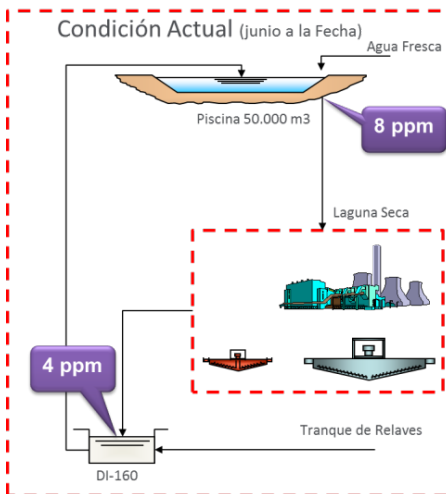
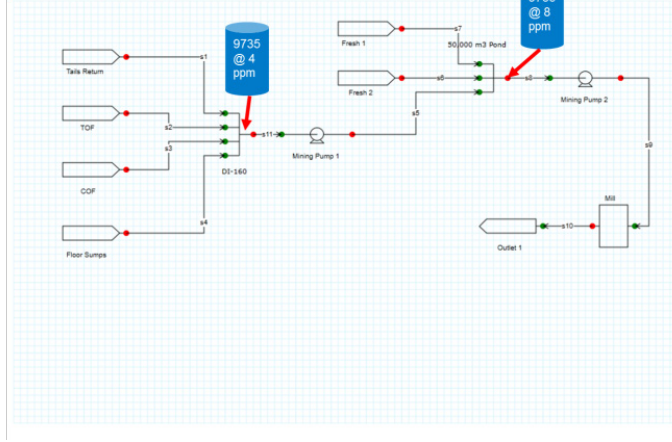
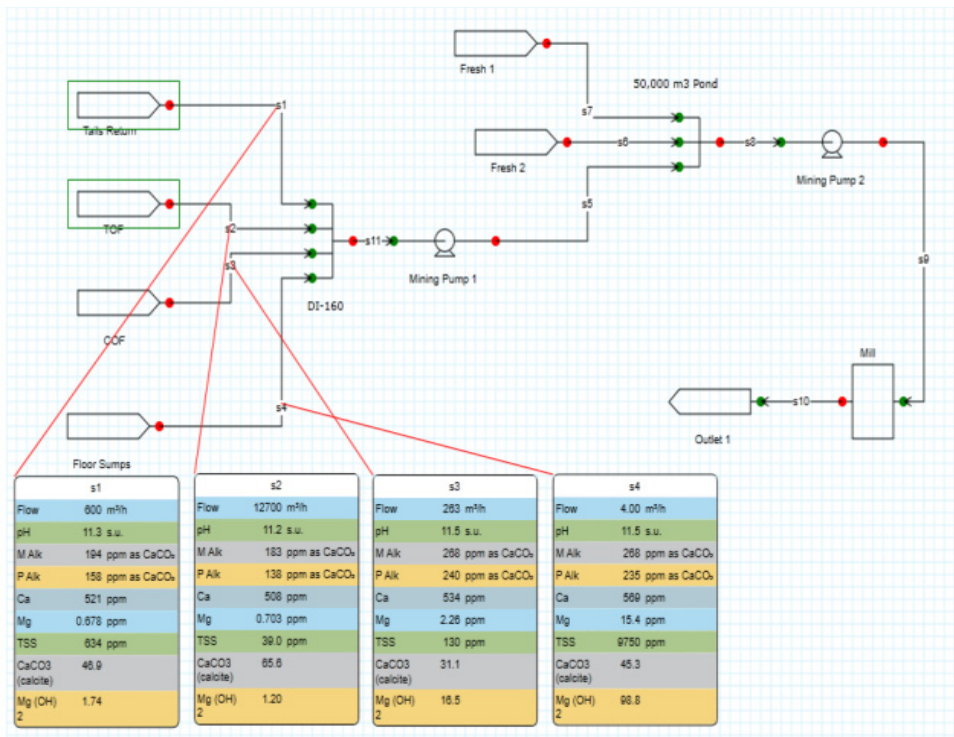

Diagram of process water system after improvement

### Ajuste de Dosis Recomendada



Nalco Water Mining Optimizer model showing dose point and dosing adjustments



**Nalco Water, an Ecolab Company**

North America: 1601 West Diehl Road • Naperville, Illinois 60563 • USA

Europe: Richtstrasse 7 • 8304 Wallisellen • Switzerland

Asia Pacific: 52 Jurong Gateway Road, #16-01 Jem Office Tower, Singapore 608550

Greater China: 18G • Lane 168 • Da Du He Road • Shanghai China • 200062

Latin America: Av. Francisco Matarazzo • nº 1350 • Sao Paulo – SP Brazil • CEP: 05001-100

Middle East and Africa: Street 1010, Near Container Terminal 3, Jebel Ali Free Zone, PO BOX 262015, Dubai UAE

[ecolab.com/nalco-water](http://ecolab.com/nalco-water)

Ecolab, Nalco Water and the logos are Trademarks of Ecolab USA Inc.  
©2019, 2023 Ecolab USA Inc. All Rights Reserved 9/23 CH-2138

**NALCO**  **Water**  
An Ecolab Company